



50X-6RZ

TRUCK-MOUNTED CONCRETE PUMP

Placing boom	B6RZ 50
Pumping unit	PU1811, double pumps
Driven by	Gearbox PTO
Chassis	4 axles



Dimensions, Reach Information Diagram, Support

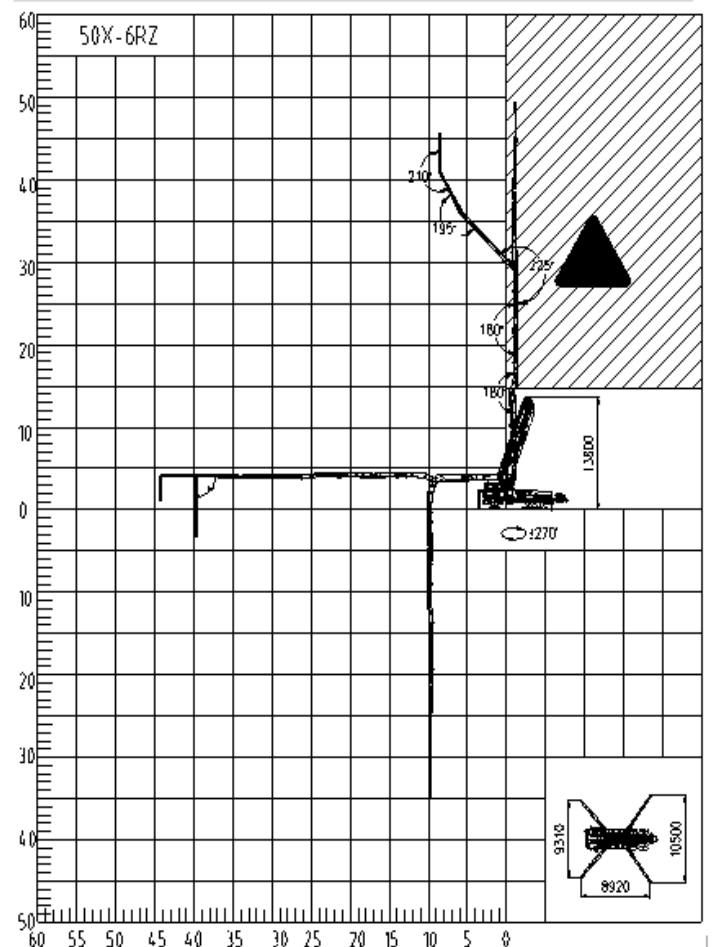
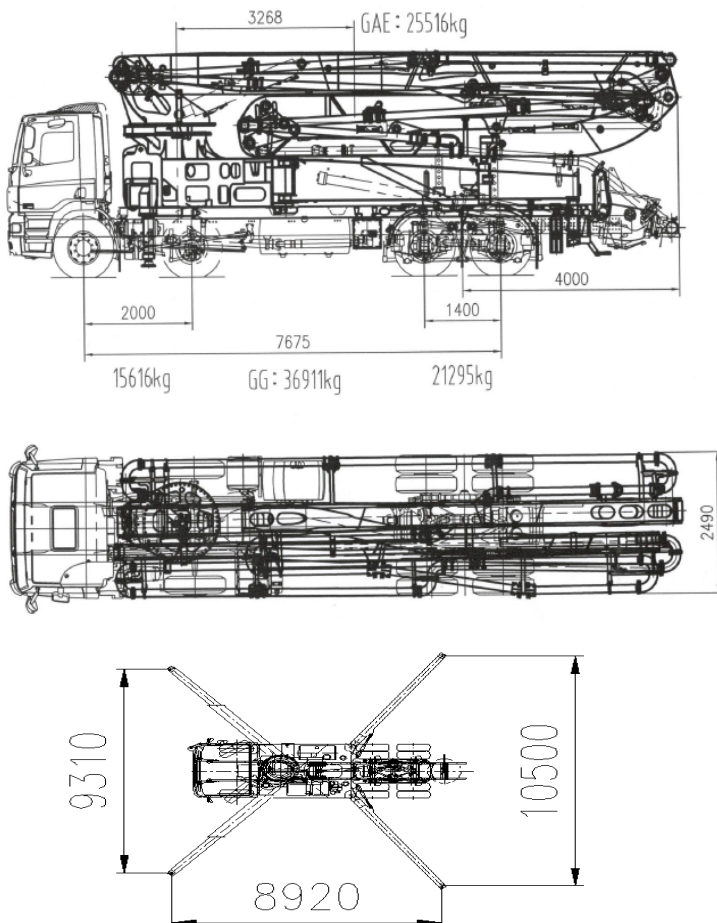



50X-6RZ

TRUCK-MOUNTED CONCRETE PUMP

Placing boom	B6RZ 50
Pumping unit	PU1811, double pumps
Driven by	Gearbox PTO
Chassis	4 axles

Main Feature

- Active boom vibration control technology(ABC):All-position active vibration reduction technology of boom, reducing vibration by 50%. More stable boom, more safety.
- Boom intelligent damping technology:The soft control of booms in starting, slewing and stopping reduces the impacting vibration of booms and therefore makes the vehicle operate more stably, reliably and safely.
- Accurate pumping control technology(APC):Great leap of pumping accuracy and adaptability, improving pump efficiency.
- Adaptive concrete material pumping technology: Improve pumping control system for poor concrete with segregation and big viscosity, and auto-adaptive pumping mode, reducing the block rate by more than 50%.
- Dual-pump and dual-loop hydraulic system: Less hydraulic impact, High efficiency, Low failure rate.
- Three-stage fault diagnosis: boot self-check, process self-check and shutdown detection is adopted to realize the overall control of the product's health condition.
- Long life wearing parts: Reduce working cost remarkably. Continuously improve wearing part's life by using new material, new process and new designing.

Standard Equipment

- Compact in design, 50m pump mounted on 4-axles truck.
- Efficient pump unit, ideal for long time use. Double hydraulic pumps.
- Agile placing boom with 6 arms with unfolding height 13.8m only, which gives a wide work range.
- Proportional radio controls with two speeds boom movement, automatic frequency scanner.
- Double thickness concrete pipes hardened.
- Centralized lubrication system for pumping unit.
- Hard carbide wear plate and cutting ring for PU pumping units.
- Fiberglass hopper covering.
- Use & Maintenance Manuals.
- Spare parts and service Manual.

Optional

- Chassis brand : Mercedes-Benz, Scania, Sinotruk, DAF ect.
- Other configuration on demand.

Placing Boom Technical Data

Model		50X-6RZ	
Pipeline diameter	mm		125
Maximum vertical reach	m		49.3
Maximum horizontal distance (from center of slewing axis)	m		44.3
Minimum unfolding height	m		13.8
Section numbers			6
1st section	Length	mm	10050
	Opening angle		90°
2nd section	Length	mm	7800
	Opening angle		180°
3rd section	Length	mm	7420
	Opening angle		180°
4th section	Length	mm	9800
	Opening angle		225°
5th section	Length	mm	5730
	Opening angle		195°
6th section	Length	mm	4500
	Opening angle		120°
Rotating angle			±270°
End hose length	m		3

Pumping Unit Technical Data

Model		PU1811	
Maximum theoretical output	m ³ /h		170
Maximum pressure on concrete	bar		88
Conc. cylinders (diam. x stroke)	mm		260x2100
Concrete hopper capacity	L		550
Hydraulic circuit			Open

